

WATT'S NEW AT HUTT ELECTRIC

"We're here to help you help your customers"

Welcome to our 189th
edition of our newsletter!

August 2010

This newsletter will provide you, our customers, with information on new technologies, products, discontinuations, etc. in the electrical industry. It will also provide you with information on any projected price increases, price decreases, and any 'special buys' at Hutt Electric Supply.

Hunt, Fish, Camp.....

SIEMENS

For the month of August, for every *individual invoice* purchase of \$1000 of Siemens residential products* , receive a **\$50.00** gift card for Gander Mountain.

* Qualifying products include all residential loadcenters, breakers, disconnects, etc. purchased through our stock. Note: job quoted orders do NOT apply to this promotion. Invoices cannot be combined to reach the goal.



Price Increases

- ♦ FERRAZ
7/1/10
- ♦ BROAN
7/1/10
- ♦ BLINE
7/1/10
- ♦ BUSSMAN
7/1/10
- ♦ AMP
7/1/10
- ♦ BRIDGEPORT
7/1/10
- ♦ CROUSE HINDS
7/1/10
- ♦ MIDWEST
7/19/10
- ♦ 3M
7/5/10
- ♦ BRYANT
7/26/10
- ♦ SIEMENS
8/2/10
- ♦ LITTLEFUSE
8/2/10
- ♦ ADVANCE
8/2/10
- ♦ MILBANK
8/16/10
- ♦ INTERMATIC
11/1/10

Closeout items and bargains ...

We have the following items at these one time special prices:

| | |
|---|------------|
| 2 - 8 ' 240v Berko 240v electric baseboard heater Minor cosmetic flaws from shipping | \$35.00 ea |
| 4 - 5 ' 240v Berko 240v electric baseboard heater Minor cosmetic flaws from shipping | \$25.00 ea |
| 50 - 5/8 x 10 ' galvanized ground rods. (m in quantity of 5) New, unused, factory shipping error | \$6.00 ea |

NEC Code Questions and Answers.....

Q. If I run PVC between the meter and service disconnect, is an equipment grounding conductor required?

A. At service equipment, the service neutral conductor provides the effective ground-fault current path to the power supply [250.24(C)]; therefore, an equipment grounding conductor isn't required to be installed within PVC conduit containing service entrance conductors [250.142(A)(1) and 352.60 Ex 2].

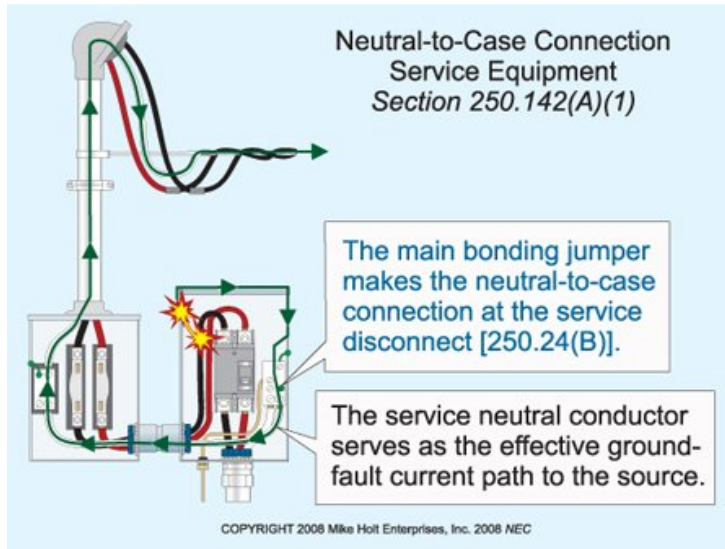

All questions and answers are based on the 2008 NEC, taken from EC&M (http://ecmweb.com/nec/code_qa/)

RENTALS

Equipment:

- ◆ Mini-Tower Scaffolding
- ◆ 22' Scissors Lift
- ◆ Tractor/ Loader
- ◆ 3-Point Disc/ Cultivator
- ◆ 3-Point 48" Brush Mower
- ◆ Tandem Axle Trailer
- ◆ Mini Excavator
- ◆ Skid Steer
- ◆ Much more.....



Daily, weekly, and monthly rate lists are available at the sales counter or online .

THE HUTT ELECTRIC TEAM

Rick Ewert (ext.13)
President, Purchasing, Sales
Kathy Ewert (ext.16)
Office Manager,
Accts. Receivable/Payable
Mike Scarpaci (ext.11)
Inside Sales and Quotes
Brian Feit (ext.14)
Outside Sales South
Lee Schreiber (ext.19)
Sales, Warehouse, and
Inventory Control
Gerry Jochimsen (ext.21)
Sales and Warehouse
Allison Luedtke (ext.15)
Office Administration Asst.
Bill Stone
Delivery
Larry Kedrowski
Delivery

Visit us online!
www.hutt-online.com

HUTT ELECTRIC SUPPLY

1200 East Ash Street
PO Box 40
Abbotsford, WI 54405
Phone: 715-223-3651
Fax: 715-223-6398
Monday-Friday
7:00 a.m.- 4:30 p.m.

